

WOW! A

Golden Age

JOHNNY THUNDER & THUNDERBOLT



BASED ON THE CHARACTERS, SITUATIONS, AND STORIES
CREATED BY *John Wentworth & Stan Schmeier*

POSABLE MODEL CHARACTER TOY of YOUR VERY OWN!

DESIGNED BY THE PROFESSOR ON CHRIS WARE'S TEMPLATE

Wow! A paper "Johnny Thunder" figure of your very own! What could be cooler? It's a new model based on artist Chris Ware's fun toy. I hope you'll get a "blast" out of it! It includes Johnny and his magical partner Thunderbolt from the Golden Age of Comics in the late 1930s and early 1940s. This model is for entertainment purposes only, and it must not be used commercially in any way!!! Now that the legal stuff is out of the way, get your tools ready, and let's get started!

STEP ONE: Study all the text instructions and building diagrams, and test fit parts before gluing together. Cut parts out along the heavy dark outlines, and use a scoring tool like an empty ballpoint pen, or a dull old butter knife. This will help create clean, sharp, folds. Most of all, take your time and have fun!

STEP TWO: First, we'll build the arms and legs of our paper superhero. Roll pieces 1-8 around a pencil or other cylinder-shaped object to get the proper curl. Next, glue them together to form tubes. If you plan to use the original spring joints, simply cut and fold the tabs into the center and glue the tube ends closed. If you are planning to string your model together with yarn, or make it posable with wire or pipe cleaners, you will need to punch holes in the flaps at the ends of each tube before gluing them closed. Then, either fold up all of the spring joints, 9-16, and attach them to the tubes following the instruction diagrams on page 2, or roll up the beads on page 3, and "string up" the pieces, with a bead at each joint.

STEP THREE: Next, fold up the torso assembly 17. Begin by making the "sardine

can" shape of the torso, then the tapered shape of the chest. If you plan to string or wire the limbs, you will need to punch holes at the shoulder and hips and run the wires or strings through before closing off the assembly. Reinforce the areas around the holes with thin cardboard. To make the head turn, don't close up the shoulder flap just yet. Glue coat inside piece 19 into place.

STEP FOUR: Next, roll up Johnny's head 20, and glue down the top flap. If you want the head to turn, you can create a neck pin (see special instructions below & diagram on pg. 3).

STEP FIVE: Assemble the "sardine can" feet 21-22 and glue them to the ends of the shin units. Fold up and glue the hands 23-24 to the ends of the arms. Johnny is now complete. Repeat steps 1-5 to build Thunderbolt's upper torso, adding the fin 19 to his head.

STEP SIX: If you are using the spring joints, attach them to the ends of the arm and leg assemblies and glue them to the torso at the shoulders and pelvis. If you are using string or wire, see the special instructions below and the diagram on pg. 3 before moving on.

STEP SEVEN: Follow the diagrams to glue thunder bolt 22-27 together. Coil it up underneath Thunderbolt's body to help support him. Stand him up next to Johnny, say the magic words "cei-eu!" - they're ready for action!

SPECIAL INSTRUCTIONS: If you decide to use string or wire to hold your model together, I suggest you strengthen the model by rolling strips of paper around a toothpick and inserting them into the arm and leg tubes before gluing them shut. This will make them "solid" while still leaving a hole to pass the string or wire through. The head can be made solid in a similar fashion, and if the paper strips are wrapped around a pencil, a large enough hole will be left to allow an axle of paper to be rolled up, inserted into the head, passed through the shoulder plate, and fixed in place with a thin strip wrapped around the end (see pg.3).

A Very Special Thanks to Artist Chris Ware for his kind permission to use his template.

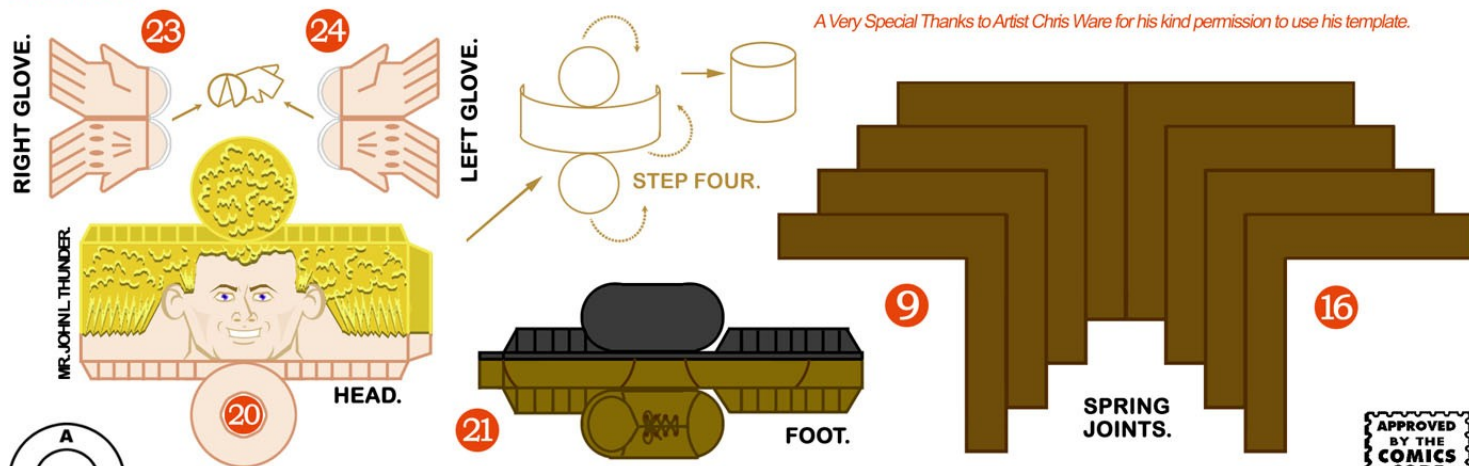
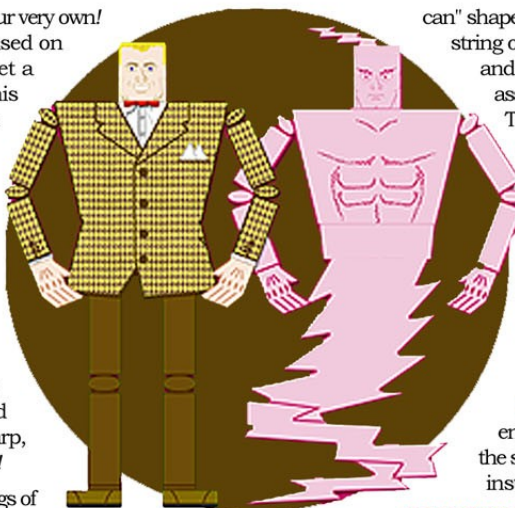

INSPIRED BY THE WORKS OF JOHN WENTWORTH & STAN SCHMEIER, AND CHRIS WARE
All DC Comics characters and the distinctive likeness(es) thereof are Trademarked & Copyrighted by DC Comics, Inc. ALL RIGHTS RESERVED.



ARM PIECES.

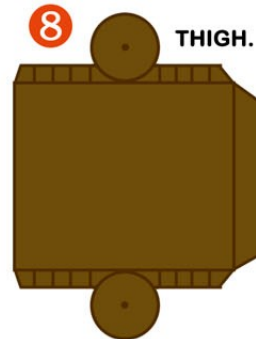
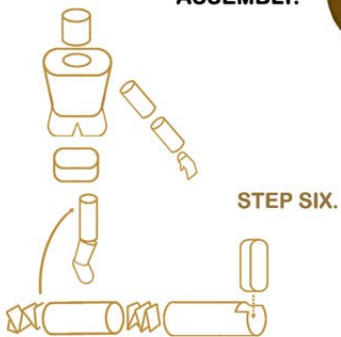
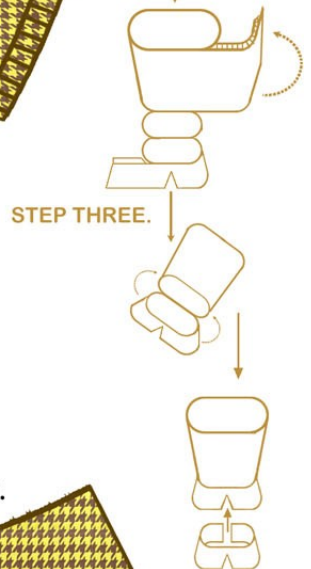
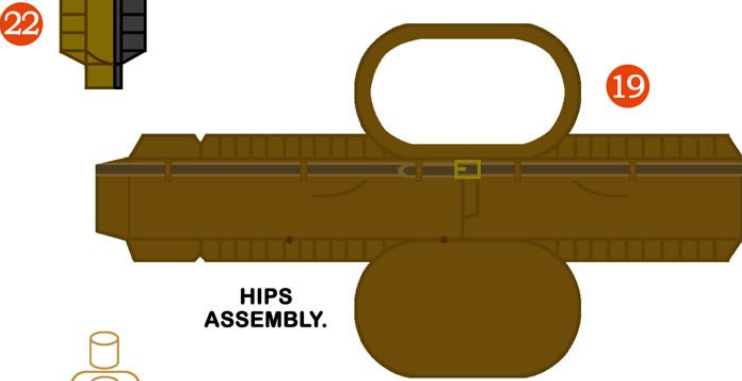
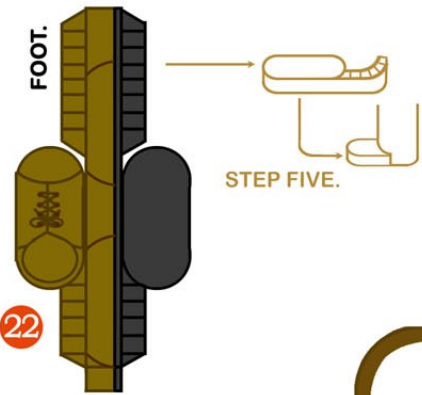
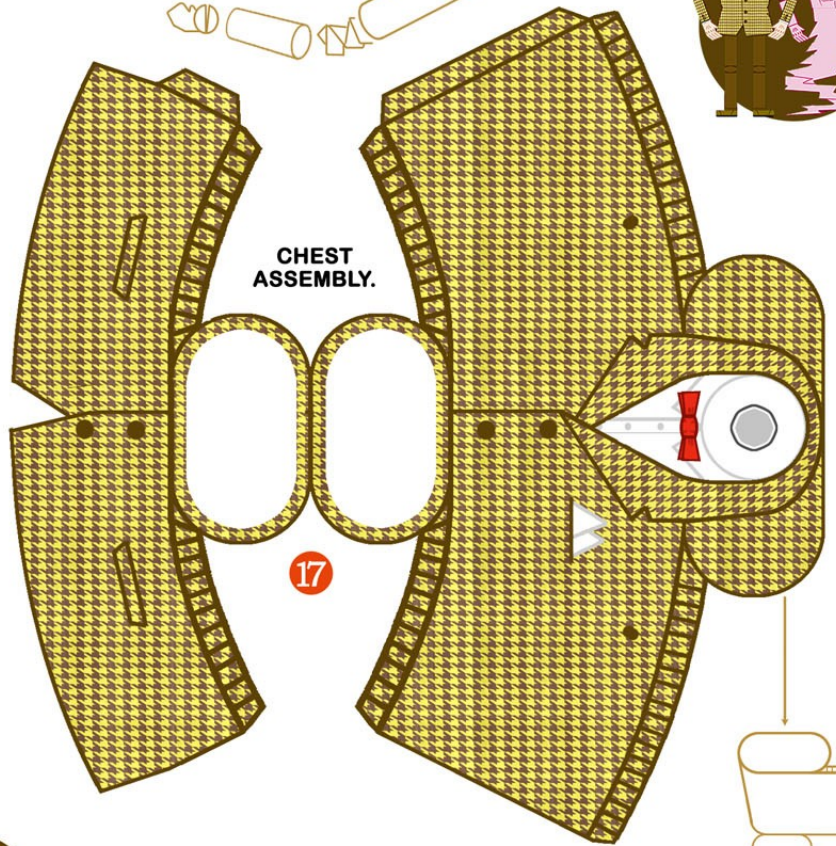
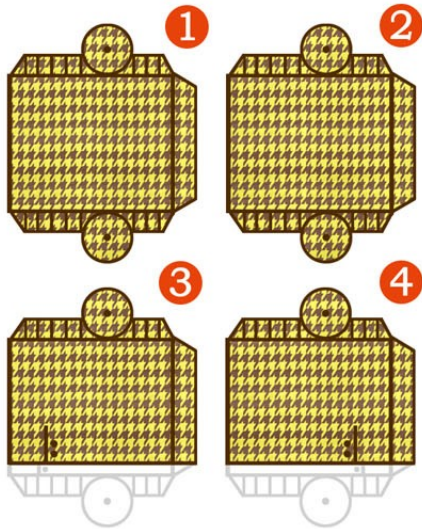



A base for your figure.



ARM PIECES.

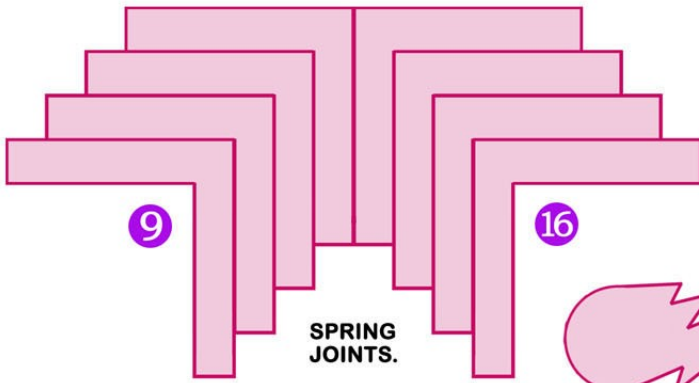
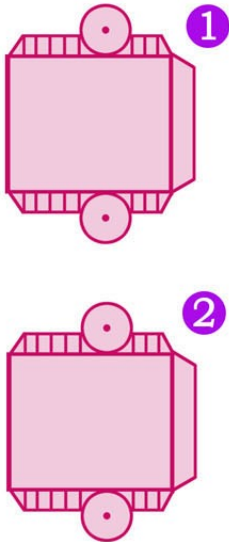

SPRING JOINTS.

LIGHTNING BOLT: C-F.

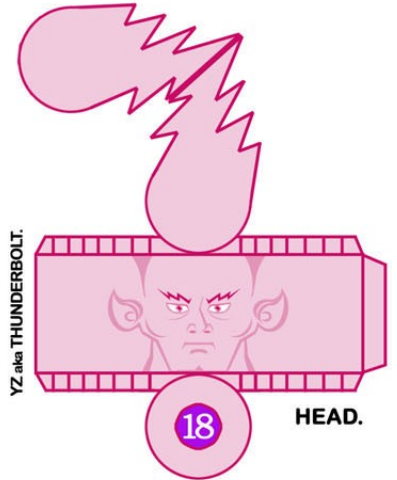
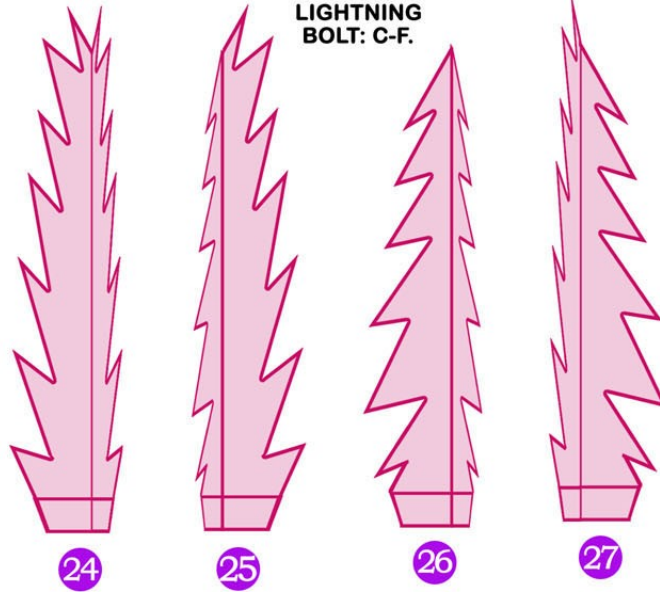

YZ, aka THUNDERBOLT.

HEAD.

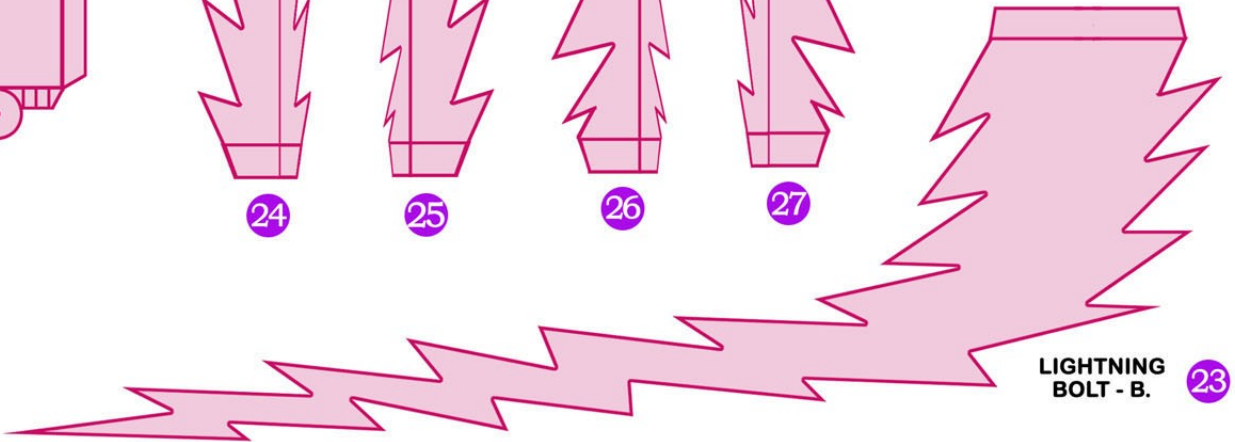

LIGHTNING BOLT - B.

Roll these triangles up around a toothpick from thick end to point and glue down to create beads to use at joints.

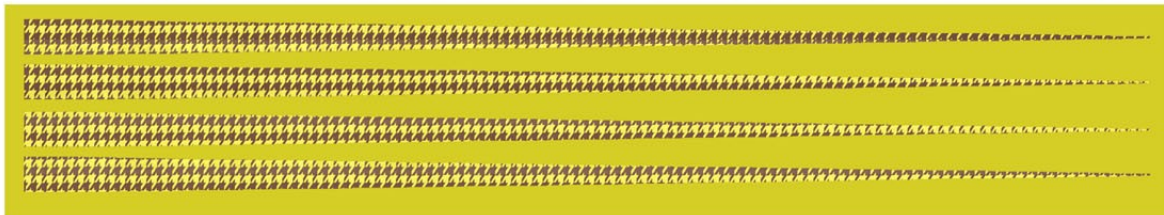

DETAIL SHOWING HOW TO RUN WIRE OR YARN THRU THE ARM & LEG PIECES; ALSO, THE NECK PIN AND "NUT" TO HOLD IT IN PLACE.

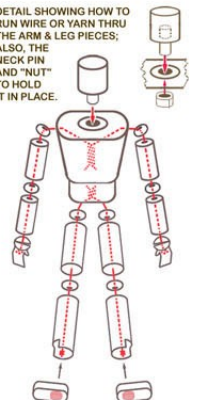

These beads are designed to be used in place of the spring joints when assembling the figure using pipe cleaners, string or yarn. Punch holes in the ends of each leg and arm cylinder and into the torso, then run the pipe cleaners, string or wire through, inserting a bead in between them at the shoulders, elbows, hips and knees. Twist or tie them off inside the torso and at the ends of the limbs, hiding the ends in the hands and feet. Use the pieces above for the shoulders and elbows; the ones below for the hips and knees.

SMALL, STRONG MAGNETS IN THE FEET WILL HELP FIGURE STAND. (ON METAL SURFACES OF COURSE!)



THUNDER BOLT

A base for your figure.



ARM PIECES.

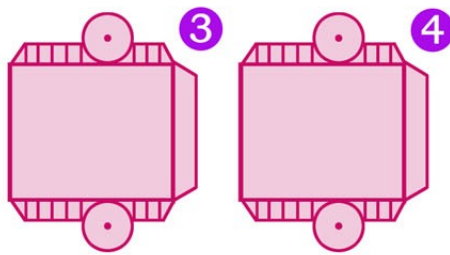

RIGHT GLOVE.



LEFT GLOVE.



CHEST ASSEMBLY.

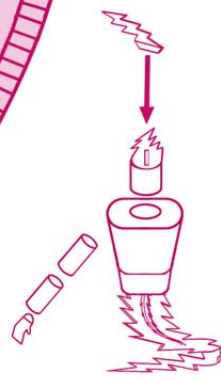
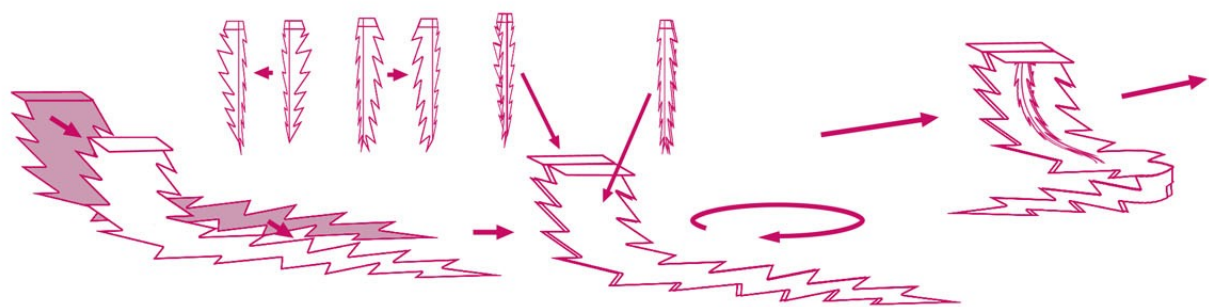
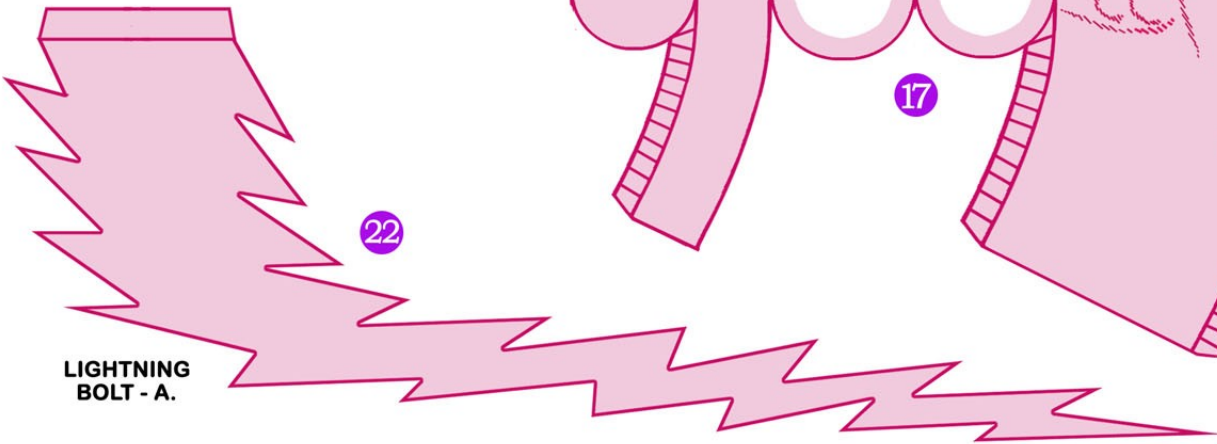
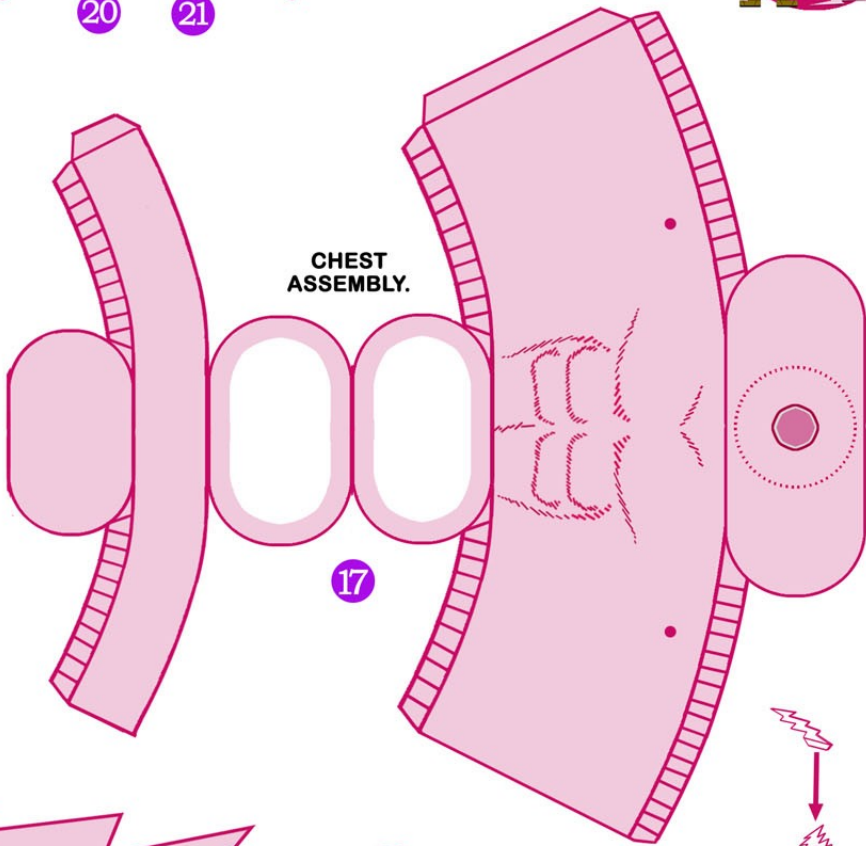

STEPS FIVE & SEVEN.

Roll these triangles up around a toothpick from thick end to point and glue down to create beads to use at joints.



DETAIL SHOWING HOW TO RUN WIRE OR YARN THRU THE ARM & LEG PIECES; ALSO, THE NECK PIN AND "NUT" TO HOLD IT IN PLACE.



These beads are designed to be used in place of the spring joints when assembling the figure using pipe cleaners, string or yarn. Punch holes in the ends of each leg and arm cylinder and into the torso, then run the pipe cleaners, string or wire through, inserting a bead in between them at the shoulders, elbows, hips and knees. Twist or tie them off inside the torso and at the ends of the limbs, hiding the ends in the hands and feet. The pieces above are for the elbows and shoulders.

SMALL, STRONG MAGNETS IN THE FEET WILL HELP FIGURE STAND. (ON METAL SURFACES OF COURSE!)